



NV9055 Instruction Manual

Remote Control Panel for NVISION

NV1055 Digital Audio Mixers

- | | |
|------------------|---|
| CONTENTS: | 1. GENERAL DESCRIPTION |
| | 2. CONFIGURATION AND
INSTALLATION |
| | 3. OPERATION |
| | 4. FUNCTIONAL DESCRIPTION |
| | 5. MAINTENANCE AND
TROUBLESHOOTING |
| | 6. DRAWINGS AND SCHEMATICS |
| | 7. APPENDICES AND CHANGE
INFORMATION |

Manual P/N MI9055-00B
February, 1997



Important Safeguards and Notices

The information on the following pages provides important safety guidelines for both operator and service personnel. Specific warnings and cautions appear throughout the manual where they apply. Please read and follow this important safety information, especially those instructions related to the risk of electric shock or injury to persons.



WARNING

Any instructions in this manual that require opening the equipment cover or enclosure are for use by qualified service personnel only. To reduce the risk of electric shock, do not perform any servicing other than that contained in the operating instructions unless you are qualified to do so.

Symbols and Their Meaning



The lightning flash with arrowhead symbol within an equilateral triangle alerts the user to the presence of dangerous voltages within the product's enclosure that may be of sufficient magnitude to constitute a risk of electric shock to persons.



The exclamation point within an equilateral triangle alerts the user to the presence of important operating and maintenance (servicing) instructions in the literature accompanying the equipment.



This symbol represents a protective grounding terminal. Such a terminal must be connected to earth ground prior to making any other connections to the equipment.



The fuse symbol indicates that the fuse referenced in the text must be replaced with one having the ratings indicated.

Symbols and Their Meaning (Continued)



The presence of this symbol in or on NVISION equipment means that it has been designed, tested and certified as complying with applicable Underwriter's Laboratory (USA) regulations and recommendations.



The presence of this symbol in or on NVISION equipment means that it has been designed, tested and certified as essentially complying with all applicable European Union (CE) regulations and recommendations.

Warnings

- Heed all warnings on the unit and in the operating instructions.
- Do not use this equipment in or near water.
- This equipment is grounded through the grounding conductor of the power cord. To avoid electrical shock, plug the power cord into a properly wired receptacle before connecting the equipment inputs or outputs.
- Route power cords and other cables so they are not likely to be damaged.
- Disconnect power before cleaning the equipment. Do not use liquid or aerosol cleaners; use only a damp cloth.
- Dangerous voltages may exist at several points in this equipment. To avoid personal injury, do not touch exposed connections and components while power is on.
- Do not wear rings or wristwatches when troubleshooting high current circuits such as the power supplies.
- During installation, grasp the chassis of the equipment firmly and lift with your legs; do not bend over at the waist to lift heavy items. Moreover, do not rely on door handles or front panels to lift the equipment as they are not intended for this purpose.
- To avoid fire hazard, use only the specified fuse(s) with the correct type number, voltage and current ratings as referenced in the appropriate locations in the service instructions or on the equipment. Always refer fuse replacements to qualified service personnel.
- To avoid explosion, do not operate this equipment in an

explosive atmosphere.

Warnings (Continued)

- Have qualified service personnel perform safety checks after any completed service.
- If equipped with redundant power supplies, the equipment has two power cords. To reduce the risk of electric shock, disconnect both power supply cords before servicing the unit.

Cautions

- When installing this equipment, do not attach the power cord to building surfaces.
- To prevent damage to equipment when replacing fuses, locate and correct the problem that caused the fuse to blow before re-applying power.
- Verify that all power supply lights are off before removing the power supply or servicing the equipment.
- Use only the specified replacement parts.
- Follow static precautions at all times when handling this equipment.
- This product should only be powered as described in the manual. To prevent equipment damage, select the proper line voltage at the AC input connector (if applicable) as described in the installation documentation.
- To prevent damage to the equipment, read the instructions in the equipment manual for proper input voltage range selection.
- To maximize protection against unwanted power loss, ensure that

the power cords for redundant power supplies are plugged into separate branch circuits.

North American Power Supply Cords

The power cords supplied with this equipment have a molded grounding plug (NEMA 5-15P) at one end and molded grounding receptacle (IEC 320-C13) at the other end. Conductors are CEE color-coded: Light blue (neutral), Brown (line) and Green or Green/

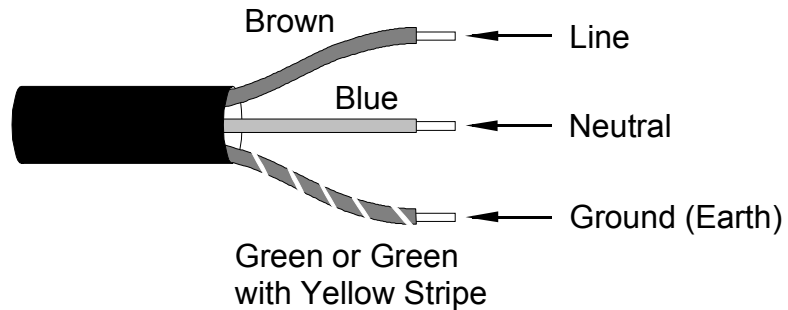

Yellow (ground).

Operation of this equipment at voltages exceeding 130 VAC will require power supply cords which comply with NEMA configurations.

International Power Supply Cords

The power cords supplied with this equipment have a molded

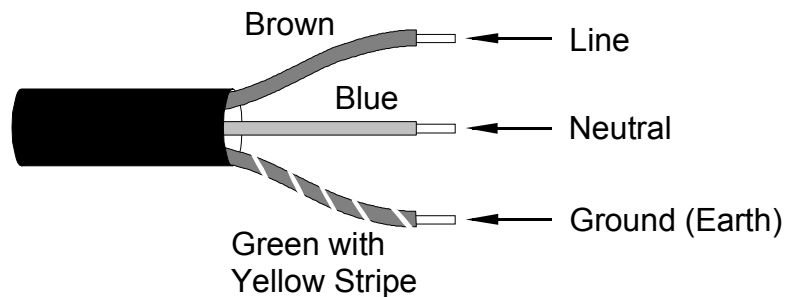

grounding receptacle (IEC 320-C13) at one end and stripped conductors (50/5 mm) at the other end. Conductors are CEE color-coded: Light blue (neutral), Brown (line) and Green/Yellow (ground). Other IEC 320-C13 type power supply cords can be used if they comply with the safety regulations of the country in which they are installed.

FCC (USA) Compliance Statement

Note: This equipment has been tested and found to comply with the limits for a Class A digital device, pursuant to Part 15 of the FCC Rules. These limits are designed to provide reasonable protection against harmful interference when the equipment is operated in a commercial environment. This equipment generates, uses and can radiate radio frequency energy and, if not installed and used in accordance with the instruction manual, may cause harmful interference in which case the user will be required to correct the interference at his own expense.



European Community (CE) Declaration of Conformance

The equipment described in this manual has been designed to conform with the required safety and emissions standards of the European Community. Products tested and verified to meet these standards are marked as required by law with the CE mark shown below.

Table 1 - NV9055 Performance Specifications

NV1055 Remote Control Port	
Number of Ports:	One.
Interface Standard:	Conforms to AMSI/SMPTE 207M-1984.
Signalling Method:	Asynchronous start/stop serial data stream, 8 data bits, 1 stop bit, no parity.
Baud Rates:	115.2 kbaud, 38.4 kbaud.
Port Connector:	Standard 9-pin female subminiature D-type connector.
Number of NV1055s Supported:	Up to 16 connected in daisy-chain configuration.
Protocol:	Conforms to NVISION RS-422 standards (Refer to NVISION RS-422 Protocol Manual, Part Number NP1055-xx, latest version.)
General Purpose (GPI) Interface	
No. of Inputs/Outputs:	Four inputs; two Form C outputs.
Interface (Inputs and Outputs):	Floating, dry contact closure.
General	
Power:	90-130 or 180-250 VAC (switch selectable), 45-65 Hz.
Power Consumption:	10 Watts.
Size:	EIA 19" rack mount; 44.5 mm H x 483 mm W x 19 mm D (1-3/4" H x 19"W x 7-1/2" D.)
Weight:	2.3 kg (5.0 lb.), NV9055 only.

1. General Description

1.1 Features

The NV9055 Remote Control Panel for the NV1055 Mix/Minus with Router program module provides full remote control capabilities for up to 16 NV1055 modules. This includes control of:

- Input channel phase (normal/inverted)
- Input channel gain
- Input channel routing and mixing
- Output channel gain

A pushbutton switch on the NV9055 Remote Control Panel selects the NV1055 module to be controlled. The status of all controllable parameters (gain, mix, phase, etc.) for the selected module are automatically shown in the control panel's display windows. A cursor controlled by a rotating knob can be used to select any one of the displayed parameters. The value of that parameter can then be changed as desired using the knob. Complete operating procedures are described in Section 3 later in this manual.

In addition to providing manual control, the NV9055 can also store several commonly-used NV1055 configurations for easy recall at a later time. This enhances the panel's usefulness by speeding up and simplifying its operation while increasing its flexibility.

Specifications for the NV9055 Remote Control Panel are presented in Table 1 on Page 2. An important Product Safety and EMI Information document is also included in Section 7 of this manual. It is important to read and understand this document before installing and operating the equipment.

1.2 Front Panel Arrangement

Refer to Figure 1 for a view of the front panel of the NV9055.

The front panel contains four groups of displays and two sets of controls. The first group of displays is the PHASE INVERTED status display. It comprises 4 bi-colored LEDs which show the phase status (normal/inverted) of each input channel. This display is located at the far left side of the panel. The second display group is a pair of back-lighted LCD display windows to the right of the PHASE INVERTED display. These show the input and output gain values for each channel on the selected mix card. The resolution of these displays is 0.1 dB. A third display group comprises four back-lighted LCD display windows. These provide the current channel mix values for all four output channels. Mix coefficients are displayed with 1 dB resolution. At the

right side of the panel, a fourth LCD display window shows the address of the module that is currently selected for display and control. This display window also shows the panel's software version number for a brief moment during a power-up cycle. Other messages, described later, are shown in this display window when appropriate.

A field of pushbutton switches on the right hand side of the panel display area enables the user to select specific control functions or to recall a stored configuration. The main control is the rotary knob at the far right. This knob controls the position of the parameter selection cursor. It is also used to increment or decrement the values of mix card parameters.

1.3 Displays

The displays described above indicate the status or value of the selected mix card's parameters. A movable cursor controlled by a front panel knob selects one of the display parameters. Once selected, a parameter can be changed by the operator using the control panel rotary knob.

INPUT PHASE STATUS

The PHASE INVERTED display consists of four LEDs, one for each input channel. If a channel's phase is normal (not inverted), its LED is extinguished. If a channel's phase is inverted, its LED is normally red.

When the parameter selection cursor is moved to the PHASE INVERTED display area, the selected channel LED turns green or orange. If the phase of the selected channel is normal, the LED is green. If the phase of the selected channel is inverted, the LED will display orange - a combination of green (selected) and red (phase inverted) - to indicate that the input channel is selected and that its phase is inverted.

INPUT AND OUTPUT GAIN

The two INPUT GAIN and OUTPUT GAIN displays function in an identical manner. Each window displays the gain amplification for all four input and output channels in increments of 0.1 dB. The location of the cursor is indicated by a blinking underline. The gain of the selected channel can be controlled throughout its full range (Silence to +12 dB) using the rotary knob. The default value for input and output gain is +0.0 dB.

MIX

The MIX display comprises four separate OUTPUT windows, one for each output channel. Within each OUTPUT window, the mix value of each of the four input channels is displayed. For example, if Input 1 is shown as +0.0 dB in the MIX display window for Output 1, then Output 1 will include 100% of Input 1's signal, including any

previously-applied input phase and gain modifications.

The default or reset value of the mix parameters for each output channel is unity gain (+0.0 dB) for its corresponding input channel and Silence for the other three inputs. For example, the default MIX value for Output Channel 1 is Input 1 at unity gain with the other three input channels set to Silence.

CARD ID

The fourth display is the CARD ID display. The NV9055 can control up to 16 separate NV1055 cards. Each NV1055 card is assigned a unique two digit identifier (01, 13, etc.). Note that NV1055 addresses are set using the switches on the front panel of the module. For information on setting addresses, refer to the instruction manual for the NV1055, Manual Insert P/N MI1055-xx. The address of the currently-selected module is displayed in the CARD ID display. The upper portion of the CARD ID display is also used as a general message display. Messages are described later, in Section 3 of this manual.

1.4 Controls

The NV9055 contains two sets of user controls: a group of pushbutton switches and a rotating knob with an integral, momentary-action switch.

The pushbutton switch legends identify their respective functions: SELECT MIX CARD, STORE, MEM 1, MEM 2, MEM 3, MEM 4, RESET, and MENU/VALUE. When a button is depressed (active), the color of the button changes from light green to amber. Depressing one button may change the display color of a previously-depressed button. This indicates that the function of that previous button was superseded by the button just selected. For example, if a user depresses MEM 1 followed by MEM 2, the MEM 2 button will show amber and the MEM 1 button will revert to green.

The SELECT MIX CARD button changes the CARD ID display, selecting the next available module address in ascending order.

The STORE button stores the current configuration of the module into memory for later recall. To store a configuration currently displayed in the NV9055 windows, press the STORE button followed by the appropriate MEM button (MEM 1, MEM 2, etc.). The selected MEM button will display amber and the STORE button will return to green when this sequence is complete.

If desired, stored values can be saved permanently (locked) by setting an internal DIP switch. Refer to Section 2 for information on accessing this capability.

MEM buttons are used to store and recall module configurations. Stored configurations are recalled by selecting the appropriate mix card and then depressing the desired MEM button. When the MEM button displays amber, the stored configuration has been applied to the current

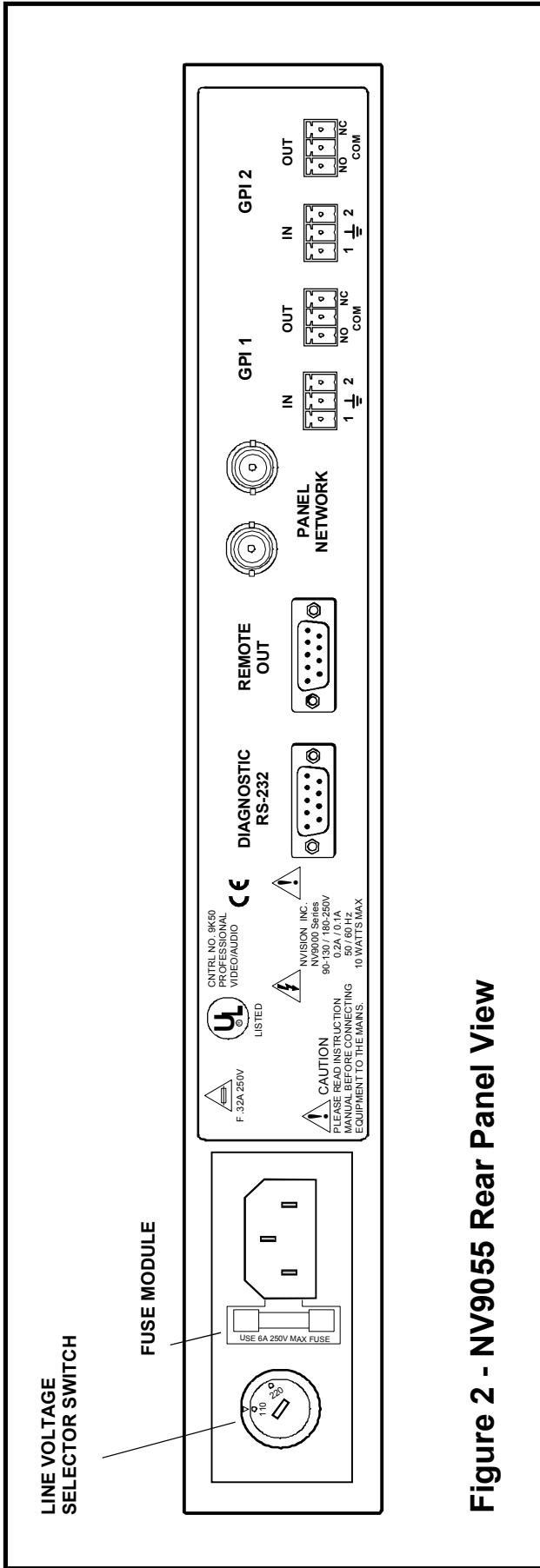
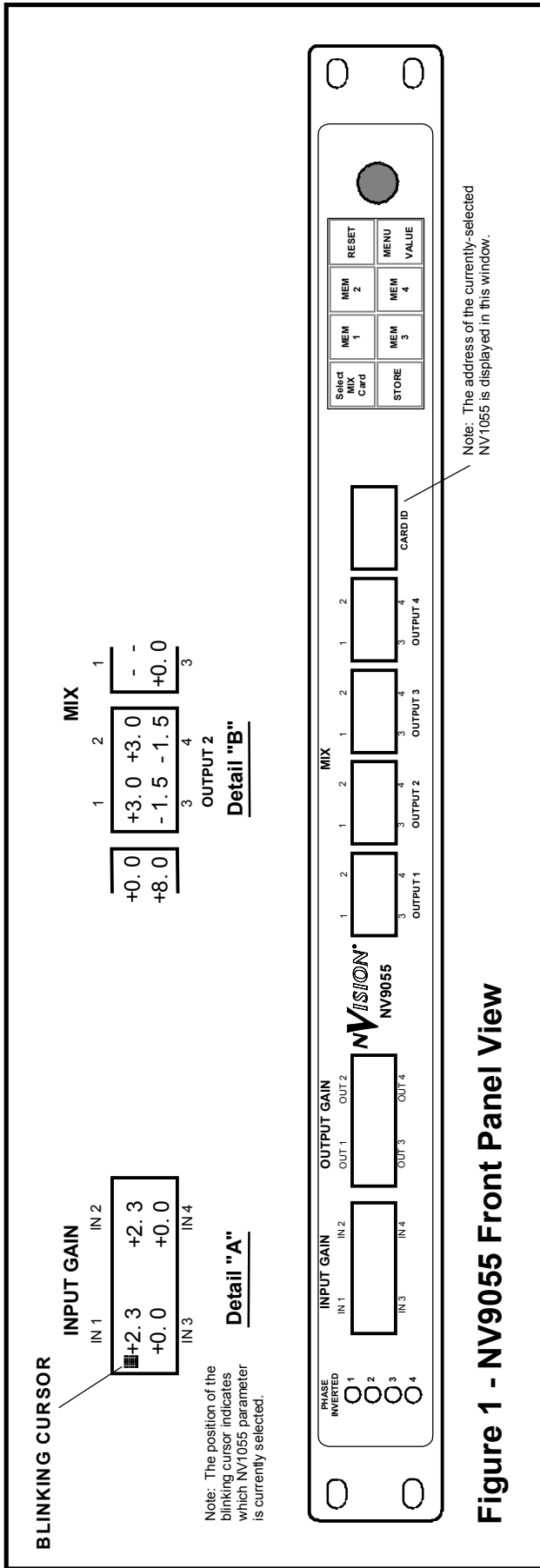

module.

The MENU/VALUE button toggles the knob's function between parameter selection (MENU) and value setting (VALUE) modes. This button is used in conjunction with the rotating knob mounted to the right. When in MENU mode, the MENU/VALUE button displays light green. Rotation of the knob while in the MENU mode moves the cursor from display to display, selecting a parameter field or window. When the VALUE mode is selected, the MENU/VALUE button changes to an amber color. Rotation of the knob in the VALUE mode alters the value of the currently-selected parameter. Depressing the knob itself duplicates the function of the MENU/VALUE button, including changing the color of the button's illumination.

Leaving the control panel in MENU mode provides a lock-out function. In this mode, an accidental movement of the knob will not alter any parameters, but will simply move the cursor.

1.5 Backplane

The NV9055 backplane is illustrated in Figure 2.

The NV9055 Remote Control Panel backplane provides connectors for the NV1055 RS-422 control port and a GPI (General Purpose Interface) interface. The remaining connectors are not used in this application.

Power enters the control panel at the far left side of the backplane using a detachable three-conductor power cord.

The 9-pin D connector labeled REMOTE OUT is used for connecting NV1055 modules to the panel using the NVISION RS-422 protocol. Up to 16 modules can be connected in a party-line or daisy-chain manner to this port.

The interconnecting cable is diagrammed in Figure 3.

General Purpose Interface (GPI) inputs and outputs are provided to increase the flexibility of the NV9055 Remote Control Panel. These are accessible from the rear panel of the NV9055 panel. GPI inputs can be used to trigger memory recalls. The output circuits are provided for a future implementation; they are not functional in the current version of the NV9055. More information on GPI operation can be found in Section 3.2.

Detailed interconnection information is located in Section 2 of this manual and in the NV1055 Serial Interface Protocol Manual (Manual Part Number NP1055-xx) located in Section 7.

2. Configuration and Installation

2.1



Configuration

SETTING THE DIP SWITCHES

Remove power from the frame when removing the cover and configuring the DIP Switch on an NV9055 Remote Control Panel.

When the NV9055 is shipped from the factory, the internal DIP switch is set correctly. To protect values stored in memory from inadvertent changes, the internal DIP switch must be reconfigured. DIP switch settings are described in Table 2 - NV9055 DIP Switch Settings and in the general setup procedures which follow:

1. Remove the cover from the NV9055 chassis.
2. Locate the eight-pole DIP Switch S344 on the main printed circuit board. This DIP switch component contains eight switches. The first switch is S344-1 and is on the end nearest the middle of the board. The eighth switch, S344-8, is on the end nearest the edge of the PC board.
3. Switches S344-1 through S344-4 are not presently used.
4. Set DIP Switch S344-5 to the OFF (default) position to configure the control panel for normal memory storage and recall using the front panel pushbutton switches.

Set S344-5 to ON to "lock" the panel's memory registers. When registers are locked, the STORE pushbutton switch on the front panel is disabled. This permits operators to set up and lock the memory registers with frequently-used configurations. When locked, the configurations are permanently stored in memory and protected from accidental change. If desired, the memory registers can be reprogrammed at a later time simply by setting S344-5 to the OFF position.

5. Switches S344-6 and S344-7 are not presently used.
6. Set S344-8 to configure how the panel is initialized when power is applied.

The NV9055 keeps its current state, including its configuration

Table 2 - NV9055 DIP Switch Settings

DIP Switch No.	Setting	Function
S344-1 to S344-4	ON	S344-1 through S344-4 are not presently used.
S344-5	ON	Locks memory registers, disabling STORE operation from the front panel .
S344-6	ON	S344-6 is not presently used.
S344-7	ON	S344-7 is not presently used.
S344-8	ON	RAM backup is disabled on power-up. Panel initializes to a default configuration in which NV1055s are set to a unity gain/straight-through configuration.
	OFF	RAM backup is enabled on power-up. Panel initializes all attached

memory tables, in CB (capacitor-backed) RAM. If S344-8 is in the OFF position, the panel will re-initialize to its former state based on the contents of CB RAM. In this mode, it will keep its configuration data intact when the power is cycled off and then on again.

If S344-8 is set to the ON position, all tables will be re-initialized to the default settings (unity gain settings, normal phase and straight-through routing).

Note that the processor checks the contents of memory for errors when rebooted. If any are found, the charge storage capacitor is assumed to have drained and the contents of the registers invalid. In this circumstance, the system is re-initialized to default values regardless of the setting of S344-8.

7. Replace the cover, securing the mounting screws which hold it in place.

SETTING THE LINE VOLTAGE SELECTOR

The NV9055 must be configured to match the incoming line voltage. To begin, inspect the line voltage indicator on the power entry module to ensure that its setting matches the nominal incoming line voltage, 110 VAC or 220 VAC. (Note: The factory default setting is 110 VAC.) If the voltage selection is not correct, proceed with the following steps:

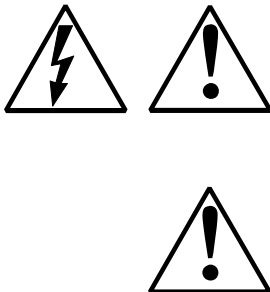

The setting of the input voltage selection should be performed by qualified personnel only!



1. Remove the power cord.
2. Insert a flat-bladed screwdriver into the slot on the voltage selection switch located on the rear face of the power entry module. Select the appropriate voltage, 110 VAC or 220 VAC.
3. Extract the fuse holder from the power entry module by inserting a flat-bladed screwdriver into the slot just inside the opening for the power cord. Gently twist the screwdriver to extract the fuse holder. Two fuses should be installed in the holder. One is the active fuse at the end of the fuse holder; the other is a spare that fits into a hole in the middle of the fuse holder.
4. Check both fuses for the correct rating. The appropriate fuse ratings are displayed on the rear panel silk-screen. If the fuse ratings are incorrect, obtain the proper fuses and insert them into the fuse holder. Replace the fuse holder and push it gently into place.
5. Confirm once again that the selected voltage level is correct.
6. If necessary, install a new line cord connector on the power cord to match the local electrical standards or codes. Insert the line cord into the power entry module. Refer to the Product Safety and EMI Information insert in this manual for proper power cord color codes.

CONTROL CABLES

Refer to Table 3 for NVISION RS-422 connector pin assignments.

The RS-422 cable between the NV9055 and NV1055s must be furnished by the user. Figure 3 provides information on how to fabricate the appropriate cable. Figure 4 illustrates the back side of the 9-pin male connectors as an aid to assembly.

For a network of control panels, a 75 ohm coaxial cable fitted with male BNC connectors is required, one for each panel. These cables should be of sufficient length to reach the next panel in the string.

2.2 Installation

Table 3 - Serial I/O Connector Pin Assignments (ANSI/SMPTE 207M)

Pin No.	Controller Pin Function	NV1055 Pin Function
1	Frame Ground	Frame Ground
2	Receive A-	Transmit A-
3	Transmit B+	Receive B+
4	Transmit Common	Receive Common
5	N/C	N/C
6	Receive Common	Transmit Common
7	Receive B+	Transmit B+
8	Transmit A-	Receive A-
9	Frame Ground	Frame Ground

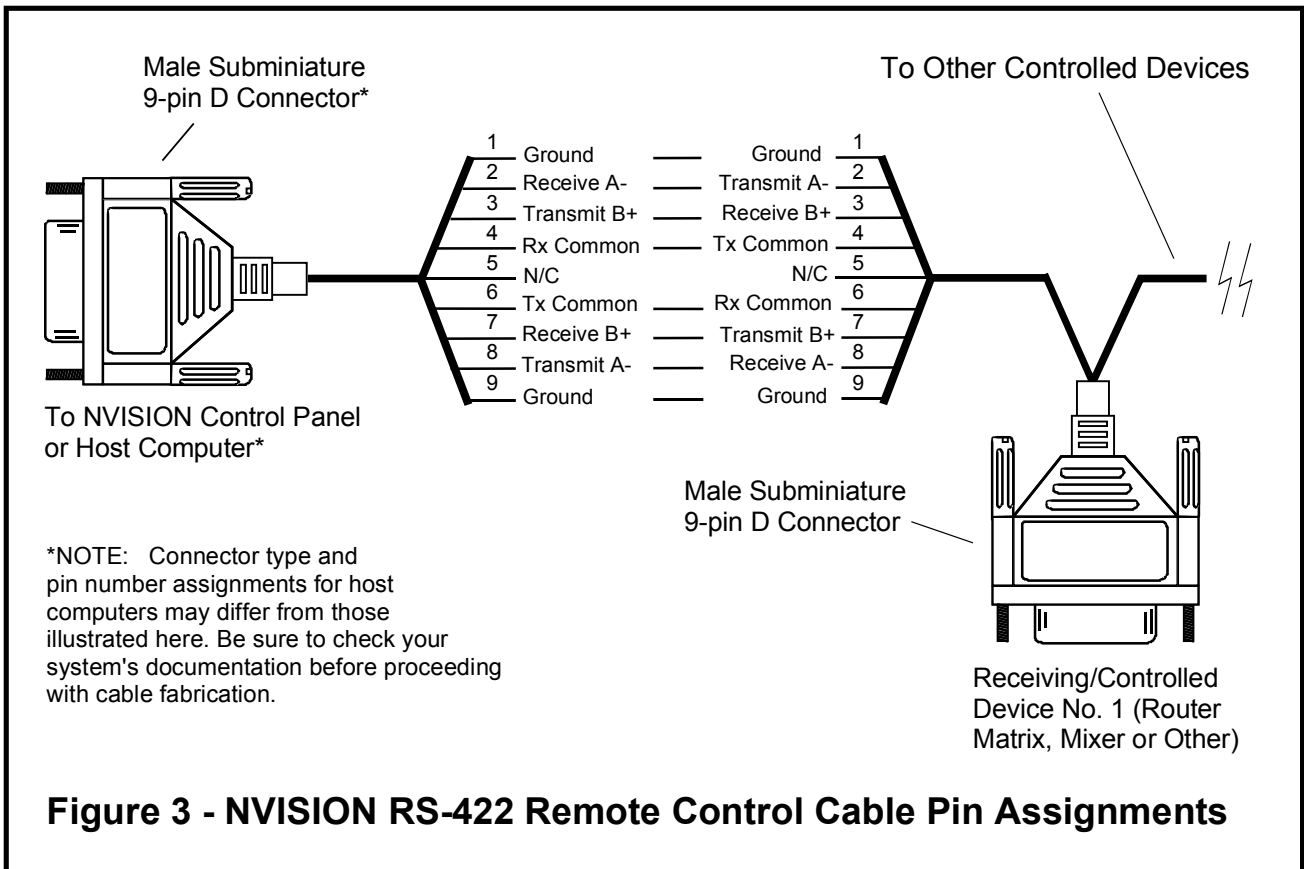
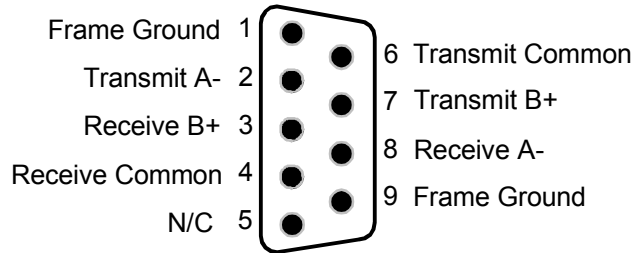

Figure 3 - NVISION RS-422 Remote Control Cable Pin Assignments

Note: The pin names below apply to connectors for controlled devices such as NVISION's Model NV1055 Digital Audio Mixers. Refer to Figure 3 for pin names for connectors for controlling devices such as the NVISION NV9055 Remote Control Panel.



Back (Solder-side) View

Figure 4 - Pin Numbers for RS-422 Male Subminiature D Connectors

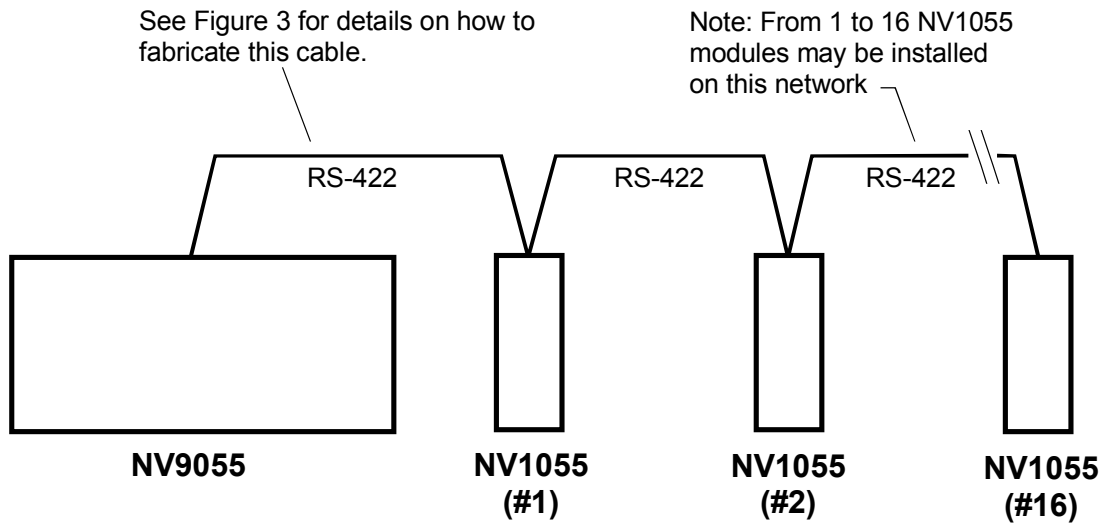

Figure 5 - Connecting NV1055 Mix/Minus with Router Modules to an NVISION NV9055 Remote Control Panel

Once configured, panel installation is straightforward. The panel can be installed in any standard 19" equipment rack.

Connect NV1055 modules to the control panel REMOTE OUT port using the specially-constructed RS-422 interface cable. Figure 5 illustrates how modules should be connected to a control panel.

3. Operation

3.1 Overview

Refer to Figure 1 for a view of the NV9055 front panel.

Before the NV9055 Remote Control Panel can communicate with more than one NV1055 module, the modules must be programmed with unique addresses. This address is set on the module itself through the front panel switches. Consult the NV1055 Mix/Minus with Router documentation (Manual Insert P/N MI1055-xx) for instructions on setting module parameters. Make sure that each module has a unique, two-digit address. If two modules have the same address, the NV9055 Remote Control Panel will return a COMM ERROR message when it polls the modules. This error is due to conflicting responses from the modules.

Configuration of a module through the NV9055 Remote Control Panel is accomplished with the panel's pushbutton switch controls and rotating knob. The rotating knob controls the position of the display cursor and functions in two modes; MENU and VALUE. The mode is selected by depressing the MENU/VALUE button or depressing the rotating knob. When in MENU mode, rotation of the knob moves the cursor through the various displays on the panel. The MENU/VALUE button displays light green when in the MENU mode. When in VALUE mode, rotation of the knob changes the value of the parameter indicated by the cursor. The MENU/VALUE button is amber when in the VALUE mode.

3.2 Controlling NV1055 Modules

The following steps are required to configure an NV1055 from an NV9055 Remote Control Panel:

1. Select the desired module.
 - a. Depress the SELECT MIX CARD button until the desired card address is displayed in the CARD ID window. If there is only one module linked to the control panel, its address will be the only one available for display.
 - b. If a module's address fails to display, the control panel was unable to communicate with the module. Confirm that the cabling is correct and that the module has power. See Section 5 -

Maintenance and Troubleshooting for further help.

2. Set the PHASE INVERTED value for each input channel.
 - a. Put the cursor into MENU mode by depressing the MENU/VALUE button (or by depressing the rotating knob) as required. The MENU/VALUE button will display light green when the knob is in the MENU mode.
 - b. Rotate the knob until the cursor appears in the PHASE INVERTED LED display group. When an input channel is selected in the PHASE INVERTED area, its LED will display green. (Note: If an input channel's phase is already inverted but not selected, its LED displays red. When selected using the cursor knob, the LED will change from red to orange (red and green) rather than just green. This shows that the channel is selected and that its current phase setting is inverted.)
 - c. Rotate the knob until the LED for the appropriate input channel is selected.
 - d. Place the knob in the VALUE mode by depressing the MENU/VALUE button or by depressing the knob. The MENU/VALUE button will display amber when in the VALUE mode.
 - e. Rotate the knob until the selected LED changes to an orange (phase inverted) or green (normal phase) color.
 - f. Switch the cursor back to MENU mode and move the cursor to the next display that requires changing. The LED for the input channel whose value was just changed will revert to a red (phase inverted) color or will extinguish (normal phase).
 - g. Repeat the above procedure for all of the input channels whose phase value needs changing. When all four input channels are set for the correct input phase, go to the next step.



3. Set the INPUT GAIN for each input channel.
 - a. In MENU mode, rotate the knob to move the cursor to the appropriate INPUT GAIN display. Check the CARD ID display for channel status messages regarding signal presence.

The INPUT GAIN display does not indicate the presence or absence of a signal on an NV1055 input channel. The user may make modifications to input gain regardless of whether or not a signal is present.

- b. Switch to VALUE mode.



- c. Rotate the knob until the correct gain value is displayed in the appropriate window.
 - d. Switch back to MENU mode and move the cursor to the next parameter to be modified. Repeat the above steps as necessary. When all of the input gains have been set, move to the next step.
4. Set the MIX parameters for each output channel.

Modifying a mix parameter modifies the level of the input signal after the input values have been assigned. For example, if a channel's input gain parameter is -3 dB and its mix value is set to -3 dB, the level of the input channel signal at the output of the mixer is -6 dB.



- a. In MENU mode, rotate the knob to move the cursor to the appropriate position in the MIX display area.
 - b. Switch to VALUE mode.
 - c. Rotate the knob until the correct mix parameter for the selected input channel appears in the display window.
 - d. Switch back to MENU mode and move the cursor to the next parameter to be modified.
 - e. Repeat the above steps until all of the mix values are set for each of the output channels. When all the mix values are set, proceed to the next step.
5. Set the OUTPUT GAIN for each output channel.

Modifying the output gain adjusts the gain of the output channel after the mix. For example, if a channel's input gain parameter is set to -3 dB, its mix value to -3 dB and the output gain is set to +6 dB, the level of the input channel will be 0.0 dB in the output channel.



- a. In MENU mode, rotate the knob to move the cursor to the appropriate channel in the OUTPUT GAIN display.
 - b. Switch to VALUE mode.
 - c. Rotate the knob until the desired gain value appears in the display window.
 - d. Switch back to MENU mode and move the cursor to the next parameter to be modified.
6. If desired, STORE the configuration in one of the memory storage

registers.

- a. Ensure that the currently-displayed module configuration is correct.

A stored configuration can be used with any module attached to the network. Hence the current CARD ID is not stored in memory as part of a STORE procedure.



- b. Press the STORE button. The STORE button will display amber.
- c. If the STORE button is pressed in error, press it a second time to abort the storage operation. The amber display will switch back to light green.
- d. Select and depress a MEM button. The MEM button will display amber and the STORE button will switch back to a light green color.

Storing a configuration to a MEM storage register will overwrite a previously stored configuration UNLESS DIP SWITCH S344-5 HAS BEEN SET TO PROTECT THE MEMORY.

- e. The selected MEM button will continue to display amber until the user does one of the following: i) Selects a different stored configuration. ii) Alters the current selection by switching to VALUE mode. iii) Selects a different module.
7. Recall a stored configuration.
 - a. Select the correct NV1055 module by depressing the SELECT MIX CARD pushbutton switch until its address is displayed in the CARD ID window.
 - b. Depress the MEM button which corresponds to the desired stored configuration. The MEM button will display amber. The stored configuration will be displayed and sent to the selected module.
 8. RESET the panel and the current NV1055 module by depressing the RESET pushbutton switch. This sets the control panel and the currently-addressed NV1055 module to their default states.

3.2 Using GPI Inputs for Memory Recalls



Closing a switch connected across the first two pins (Pins 1 and 2) of GPI Input 1 on the rear panel of the NV9055 initiates a memory recall. The stored configuration is sent to the currently-selected mixer module. Opening the same connection recalls and sends a second stored configuration. Using GPI Input 2 in the same manner, two additional

Table 4 - Recalling Setups from Memory Using GPI Inputs

GPI Port	Switch	Action Taken
GPI 1 In	Short Pins 1 & 2	Recalls and sends the configuration stored in MEM 1 to the currently-selected NV1055 mixer.
GPI 2 In	Short Pins 1 & 2	Recalls and sends the configuration stored in MEM 3 to the currently-selected NV1055 mixer.

memory recalls can be sent. Refer to Table 4 on the next page for details on using the GPI inputs.

The memory recalls issued using GPI Input signalling are sent to the currently-selected mixer. TO AVOID sending commands to the wrong mixer, always TAKE STEPS TO ENSURE that the CORRECT mixer is selected before using the gpi input.

3.3 General Messages

FOUND: When the NV9055 first powers on, it searches the network for NV1055 mix modules and builds a table of valid addresses. The value returned (##) is the number of unique module addresses found on the network.

DEV ##: Device Number. The value displayed (##) is the address of the currently selected module. When first powered on, the module with the lowest address is the first selected.

NEW ID: A new NV1055 with the address ## has been attached to the control panel.

GONE: The module with address ## has not responded after 10 polling cycles (about 2-3 seconds).

3.4 Error and Status Messages

If a problem exists with the currently-selected mix module, a error/status message will be displayed in the upper portion of the CARD ID display, above the module address. These messages are described below.

COMM ERR.: Communication error. The last command sent to the selected module was not executed. A status command was sent. The current status of the mix module was returned and is now displayed.

BAD CMD: There was a error in the protocol. The command byte sent to the mix module is unknown.

CHA ERR: A channel status error has occurred in an incoming data stream.

COMM2ERR: An error was found in the data received by the mix module.

NO AES12: There is no signal on Input 1/2 of the mix module. Without a valid AES/EBU signal on Input 1/2, the NV1055 cannot lock and no data is passed.

NO AES34: The AES/EBU data on Input 3/4 has gone away. The NV1055 will continue operating.

BIPHAS12: A bi-phase error has been detected on Input 1/2. This is sometimes detected before the loss of lock when the AES/EBU signal is suddenly removed.

BIPHAS34: A bi-phase error has been detected on Input 3/4. This is sometimes detected before the loss of lock when the AES/EBU signal is suddenly removed.

PARITY12: A parity error has been detected on Input 1/2.

PARITY34: A parity error has been detected on Input 3/4.

SAME MIX: The NV1055 has been set to mix a channel with itself.

CONSUMER: Channel status indicates that the Consumer bit in the Channel Status is set. This is changed to Professional in the output of the mix module.

NONAUDIO: The Non-audio Channel Status bit is set. This is changed to Audio in the output of the mix module.

EMPHASIS: The Channel Status emphasis bits do not match on the channels being mixed. The highest value of emphasis is chosen and used in the output data stream.

DIFF FRQ: Input channels have different sample rates and cannot be mixed.

AUX BITS: The auxiliary sample bits have encoded data. The mix module always outputs 24 bit data.

CH STAT: An error has been detected trying to read the channel status hardware. This may be a system/hardware failure.

EE ERROR: The NV1055 tried to power on with backup from EEPROM and an error was found in the data. The NV1055 re-initialized to its default state.

4. Functional Description

4.1 Polling the RS-422 Network

The panel remote control signal is a party-line variant of an RS-422 communications link. The interface protocol is described in the NVISION RS-422 Protocol Manual (Manual Part No. NP1055-xx) for the NV1055 Mix/Minus with Router. A copy of this document is included in Section 7 of this Manual Insert.

NV1055 modules are connected in daisy-chain fashion across the RS-422 transmit and receive lines. Each module receives all of the messages sent by the control panel, responding only to those with a matching address. When a valid message is accepted, the targeted module activates its transmit output and responds appropriately.

When power is supplied to a NV9055 Remote Control Panel, it polls the network for the presence of modules on the cable. This polling provides the panel with the addresses of all active modules. If a module does not have power or is otherwise not functioning, the module will not respond to the poll request. When polling is complete, the panel creates a table of active and inactive module addresses.

After power up, the panel continues to poll the network and will alert the operator if a module is added to or removed from the network. Sections 3.2 and 3.3 list the various messages that the control panel will display if modules are added or removed from the network or if a module's status changes for other reasons.



Control Panel CPU / Communication Main Board

Refer to the schematic diagrams in Section 6 of this Manual Insert.

Two sets of schematics are included in Section 6. The main microprocessor module (Control Panel CPU / Main Communication Board) is described by the 6-page

schematic diagram for Assembly EM0084-02. The front panel displays and control PCB (Mix Minus Control Panel Active Module) is described by the two-page schematic diagram for Assembly EM0085.

Assembly EM0084-02 is a general purpose microprocessor board used in several models of NVISION control panels. Some circuitry may not be used in a particular application, depending on the functionality and complexity of the product.

MICROPROCESSOR OPERATION

Refer to Sheet 1 of the schematic diagram for Assembly EM0084-02.

Microprocessor U25 is a Motorola 68HC11A1 CPU which provides the panel's control logic and communicates with panels, modules and GPI control devices on the panel's network/GPI port(s). The processor is reset by U506 (RSTb, Pin 17) when the +5 VDC supply falls below the IC's voltage threshold, approximately 4.3 volts. Another microprocessor reset circuit (IC U505) is connected along with U506 in a "Wired-OR" configuration. A High During Configuration (HDC) signal from the FPGA and the time-delay components (R509, C511) associated with U505 hold the processor in reset mode on power-up while FPGA (Field Programmable Gate Array) U369 is initialized.

IC U19 is an EEPROM which provides the microprocessor instruction code and the configuration data for the Xilinx FPGA shown on Sheet 2.

Integrated circuit U24 is a tri-state data latch used to multiplex the least significant byte (A(0) - A(7)) of the processor's 16-bit address bus with the panel's 8-bit data bus. Multiplexing is controlled by the microprocessor's AS (Address Strobe) signal on Pin 4.

Three logic gates in IC U630 are arranged to provide control signals (Output Enable NOT) and Write Enable NOT) used elsewhere on the module. A fourth gate in this package buffers and amplifies the crystal oscillator signal (U630, Pin 3) for use as a clock signal fed to U369, the Xilinx FPGA on Sheet 2, and for the gated burst signal used to communicate with other panels (See Sheet 4 for details).

FIELD PROGRAMMABLE GATE ARRAY (FPGA)

Refer to Sheet 2 of the Schematic Diagram for Assembly EM0084-02.

The Xilinx FPGA shown on this page (U369) is a complex logic device which is programmed on power-up from code stored in EEPROM U19 depicted on Sheet 1. A detailed description of the logic functions performed by U369 and its associated components shown on this page

is beyond the scope of this Manual Insert.

CAPACITOR-BACKED RAM

Refer to Sheet 3 of the schematic diagram for Assembly EM0084-02.

Integrated circuit U352 is a CMOS RAM memory IC capable of storing 32 kBytes of data. Its supply voltage is derived from the voltage retained on charge storage capacitor C347. The charge on C347 is supplied by emitter-follower Q366. When Vcc falls to zero, Q366 is cut off and its base-emitter junction reverse-biased, preventing charge leakage in the reverse direction.

Integrated circuit U351 is a low-current CMOS RAM backup controller IC. This device detects a low supply voltage condition ($V_{cc} < 4.75$ VDC) and switches to the backup voltage source, C347 in this case. If no write cycle is in progress, the chip select line (CEOb) immediately deselects RAM IC U352, putting it into a low power consumption (HOLD) state. If power is lost during a memory write cycle, U351 prevents corrupt data from being written into RAM. During a write cycle, address line A(15) is held in the LOW state. If power fails during this time, the Pin 6 output (CEOb) of U351 is kept HIGH, keeping RAM enabled until the write cycle is completed and A(15) returns to the HIGH state. At that time, RAM is switched to the HOLD mode.

DIP SWITCH U343

Refer to Sheet 3 of schematic diagram EM0084-02.

DIP Switch S344 is used to set the panel's Source Address and several other functions. Refer to Section 2.1 of this manual insert for detailed instructions for setting S344.

U343 is a tri-state inverting buffer/line driver IC which resides across the microprocessor data bus, D0-D7. Resistor network RN345 pulls U343's data input lines towards a HIGH state. When a switch in DIP Switch S344 is ON, the corresponding data line is pulled LOW. During a DIP Switch read cycle, control line DIP-SW enables U343, placing the buffered data representing the switch settings onto the data bus.

SERIAL COMMUNICATIONS CIRCUITRY

Refer to Sheets 4 and 5 of the schematic diagram for the EM0084-02 circuit board assembly.

Integrated circuit U52 is not presently used.

IC U57 is a Dual Universal Asynchronous Receiver/Transmitter (DUART) circuit which, in conjunction with the microprocessor, formats data to and from the RS-422 port. Line driver U67 (TxDB-/TxDB+) and line receiver U63 (RxDB-/RxDB+) provide the

communications interface between U57 and the RS-422 port, a subminiature 9-pin D-type connector (J97, Sheet 5) at the rear edge of the module.

Transformer T660 and associated components (U63, U632, U67 and associated resistors and capacitors) are not used in this application.

FRONT PANEL / MICROPROCESSOR ASSEMBLY INTERFACE

Refer to Sheet 5 during the discussion which follows.

Connector J1 is a 26-pin connector which mates with the NV9055 front panel printed circuit assembly. Control and status data is transferred to and from the front panel assembly across this connector.

Integrated circuit U97 is a bi-directional tri-state bus transceiver. It provides two-way data transfers between the microprocessor and the front panel assembly. Eight-bit data on the bus is written into front panel LCD displays and the data latches which drive the pushbutton switch LEDs. Data from the keyboard scanner IC (U6, described later) on the front panel assembly is returned on this bus as 4-bit data.

IC U98 is a line driver/receiver IC which provides the gated strobe signals for the front panel displays and latches. The strobe signals drive latch enable, read/write and/or chip select pins as required.

The output signals from the front panel encoder are transferred directly across J1.

GPI INTERFACE

Four GPI inputs appear on the rear panel of the NV9055 Remote Control Panel. Arranged in pairs, the currently-implemented inputs appear on Pins 1 and 2 of Connectors J102 and J105. A contact closure or removal of a closure between an input pin and ground (Pin 2 on either connector) signals the microprocessor that an external GPI input command was received. U330, a quad EIA-485 line receiver IC, is configured as four voltage comparators, each driven from a GPI input pin. These comparators translate the GPI contact closures into logic-level signals.

Two GPI output channels are also provided but are not presently used. These circuits are provided for a future implementation; they are not functional in the current version of the NV9055.

POWER SUPPLY

Refer to the bottom of Sheet 5 for a discussion on the NV9055 power supply circuit.

Input power (110 VAC or 220 VAC) enters the NV9055 main board via J110. Transformer T11 and the full-wave bridge comprising rectifier

diodes D1064-D1067 convert the alternating input voltage to low-voltage DC. Rectifier filter capacitors C937 and C501 reduce noise and ripple at the output of the bridge. The rectified and filtered voltage is applied to U934, a +5 VDC voltage regulator circuit. Inductor L940 and capacitor C500 provide additional filtering for the regulated +5 VDC (Vcc) output. Schottky diode D500 protects the regulator from reverse voltages that can be generated by the inductive action of L940 when the input voltage or the load is suddenly removed.

MISCELLANEOUS CIRCUITRY

Refer to Sheet 6.

The connectors and data latches on Sheet 6 of the schematic diagram (EM0084-02) are included for general purpose use in other NVISION products. These components are not used in the NV9055.

4.3 NV9055 Front Panel Circuit Board Assembly

Refer to the two-page schematic diagram for the NV9055 Mix/Minus Control Panel Active Module (Assembly EM0085-02) in Section 6.

The front panel circuit board assembly is connected to the microprocessor main board in the NV9055 Remote Control Panel via connector J1, shown on Sheet 2 of the schematic diagram.

PUSHBUTTON SWITCH CIRCUITRY

The eight SPST pushbutton switches (SW1-SW8) on the NV9055 front panel are wired in an 4x4 array, with each switch connected across a unique row and column combination. The momentary-action switch in the rotary encoder, SW20, is wired in parallel with SW1, duplicating its function. The rows and columns of this pushbutton switch matrix are scanned by IC U6, a keyboard encoder IC. A closure of any switch connects a row in this array (Xn) to a column (Yn). The encoder IC detects these contact closures and codes the number of the closed switch as a 4-bit nibble. This switch closure data (D0-D3) is passed to the microprocessor on the main module along with an interrupt from the Data Available flag, PA1/IC2. The processor then takes the appropriate action.

Each pushbutton switch is illuminated by a bi-color LED lamp. When current flows in one direction through the LED assembly, the lamp is amber. When the current flow is reversed, the lamp is green. When no current flows, the lamp is extinguished.

The direction of current flow in the switch LEDs is controlled by the data latched in ICs U4 and U5. These circuits are octal D-type flip-flops. Lamp data is written into these latches from the microprocessor on the NV9055 main board. The Q outputs of the latches are paired in a differential configuration to drive each switch LED assembly. For example, the LED assembly in SW1 is connected across the Q0 and Q1 outputs of U4. If a logic LOW (0) is written into D0 and a logic HIGH (1) is written into D1, the Q0 output is held at a logic LOW level (near 0 volts) while the Q1 output is switched to a logic HIGH level, near +5 VDC. In this state, current flows from Pin 18 (Q1) of U4 into Pin 6 of SW1. It leaves SW1 on Pin 5 and returns to ground through Pin 19 (Q0) of U4. Current flow in this direction illuminates the green LED in the switch. If the data is written into D0 and D1 in a complementary form (a binary 10 instead of 01), current flows the opposite direction through the LED assembly, causing it to illuminate with an amber color. Writing a 00 or a 11 into the Q0, Q1 output turns off the LED in the switch.

FRONT PANEL LCD DISPLAYS

Two LCD display modules (U2 and U3) are used to span the display windows on the front panel of the NV9055. Display module U2 is a 2x24 (two rows by twenty-four characters per row) LCD module. It provides the INPUT GAIN and OUTPUT GAIN display function. Display module U3 is a larger 2x40 (two rows by forty characters per row) display used to show MIX and CARD ID values. Both General and Error/Status messages are displayed by U3 in the area above the CARD ID readout.

The layout of the front panel requires that some characters in the LCD display modules be hidden from view. This is of no consequence since a sufficient number of visible character positions are available. The display values are simply formatted by the microprocessor to appear in the correct positions in the display windows. This gives the operator the impression that the various display windows are independent devices when in fact they are not.

The data for the two LCD displays is conveyed on the eight-bit data bus and written into the display modules where it is latched for viewing. Potentiometers R114 and R113 adjust the display contrast for U2 and U3 respectively. They are factory-adjusted for best viewing conditions. Resistors R12 and R92 control the back-light LED current for U2; R11 and R91 provide a similar function for U3.

PHASE INVERSION LEDS

LED assemblies D1-D4 provide PHASE INVERTED status indication for NV1055 input channel 1-4. Each diode assembly is a three-leaded device containing red and green LEDs. Unlike the bi-colored diode assemblies in the pushbutton switches described earlier, the two LEDs in each of the PHASE INVERTED LEDs can be illuminated at the same time. Drive current for the diode assemblies is derived from U16's

Q outputs, based on data latched by the microprocessor on the NV9055 main board. Note that, if the phase of the currently selected input channel is inverted, both the red and the green LEDs in the corresponding diode assembly will be illuminated, showing an orange color. If the channel's phase is inverted but the channel is not selected by the MENU knob control, only the red LED will be illuminated. If the channel phase is normal and the channel is selected, just the green LED will be illuminated. Finally, if the phase is normal (not inverted) and the input channel is not selected, both LEDs will be extinguished.

ROTARY ENCODER

A rotary encoder (SW20) controls the position of the menu cursor and sets values when in the VALUE mode. Two output lines, PA0_0 and PA7_0, provide the encoder count and direction of rotation to the main board microprocessor. An integral, momentary-action switch is wired in parallel with SW1 and performs the same MENU/VALUE selection capability.

5. Maintenance and Troubleshooting

The Model NV9055 Remote Control Panel is designed to function continuously without the need for periodic maintenance. Should the panel appear to malfunction, the following procedure should help to isolate the problem:

1. Review the NV9055 DIP switch settings (S344) to ensure that they are correct. Refer to Section 2.1 for detailed instructions on how to configure the NV9055 panel.
2. Ensure that all NV1055 modules on the RS-422 network have been assigned unique addresses and that they are configured for the proper baud rate. Detailed setup information can be found in the NV1055 manual insert, Manual Part No. MI1055-xx.
3. Carefully check the integrity of the RS-422 cable connecting the NV9055 control panel to the NV1055 module(s). See Table 3 and Figures 3 and 4 presented earlier in this manual.
4. Test the control panel's REMOTE OUT port to ensure that the RS-422 communications link is good.
 - a. Remove all control cables and the power cord from the rear of the NV9055 chassis.
 - b. Connect a known-good NV1055 module to the control panel's REMOTE OUT port. Use a short interconnecting cable known to be wired correctly.
 - c. Power up the NV1055 module and ensure that it is operating. The network address assigned to the module should appear in

Table 5 - How to Reach NVISION Technical Support

Telephone:*	+1 916 265 1000
Facsimile:	+1 916 265 1021
Mail:	NVISION, Inc., P.O. Box 1658, Nevada City, CA 95959, USA
Shipping:**	NVISION, Inc., 125 Crown Point Court, Grass Valley, CA 95945 USA

*Available from 8:00 a.m. to 5:00 p.m., M-F, California (USA) Pacific Time Zone

**Material Return Authorization required.



the 4-character LED display.

- d. Apply power to the NV9055 control panel by reinserting the



power cord. The CARD ID display on the panel should indicate that one module was found on the network. It should have an address matching that displayed in Step 2(c) above.

- e. Depress the MENU/VALUE switch on the front panel of the NV9055. Rotate the knob to change whichever parameter is currently selected. The LED display on the NV1055 should now read RMT, indicating that the NV1055 received and acknowledged the parameter update commands. If the NV1055 failed to respond to the parameter value changes, verify the DIP switch and baud rate settings on both devices. Recheck the cable to make certain that it is wired correctly. If everything is in order, contact NVISION Technical Support (See Table 5 - How to Reach NVISION Technical Support) for assistance. Note that a Material Return Authorization number issued by NVISION is required before a defective item can be returned for warranty service or repair.

6. Drawings and Schematics

7. Appendices, Protocol and Change Information

Applicable technical data, Application Notes and Field Modification Notes that pertain to the NV9055 Control Panel are located here. These

